

24-0 BB (101692B-A)

**PLEASE READ  
BEFORE  
USING THIS EQUIPMENT**

**ECONO<sup>®</sup>LINE**

**FOR OPTIMUM  
PERFORMANCE  
THIS MACHINE  
MUST BE  
OPERATED WITH  
DUST COLLECTION  
SYSTEM.**

# Econoline Abrasive Products

## OPERATING INSTRUCTIONS & PARTS MANUAL BLAST CABINET

---

PLEASE READ THESE INSTRUCTIONS CAREFULLY BEFORE ATTEMPTING TO ASSEMBLE, OPERATE OR SERVICE THIS BLAST CABINET. FAILURE TO COMPLY WITH INSTRUCTIONS COULD RESULT IN PERSONAL INJURY AND/OR PROPERTY DAMAGE!

RETAIN INSTRUCTION FOR FUTURE REFERENCE.

---

# UNPACKING

When unpacking blast cabinet, inspect unit carefully for any damage that may have occurred during transit.

### **GENERAL SAFETY INFORMATION**

Follow all electrical and safety codes, as well as the national electric code (NEC) and OSHA.

**Do Not** operate cabinet or air flow with cabinet door or top open.

**Do Not** use fluids or mix fluids with blast media for blasting. This cabinet is designed to accommodate dry blasting media only.

### **DO NOT USE SAND IN THIS MACHINE – USING SAND WILL VOID THE WARRANTY**

Keep floor around machine cleaned of media. Most forms of blasting materials are very fine and consequently slippery.

Important – check and clean your dust collector frequently

Do not exceed maximum operating pressure of 125 PSI.

**WARNING: DO NOT OPERATE CABINETS, OR AIR FLOW WITH CABINET DOOR OR TOP OPEN. THIS COULD RESULT IN SKIN DAMAGE, SERIOUS EYE DAMAGE OR BLINDNESS IF THE BLAST WERE TO COME IN CONTACT WITH UNPROTECTED PARTS OF THE BODY.**

**WARNING: THIS IS A DRY-BLAST UNIT, IT IS NOT MADE TO ACCOMMODATE MOISTURE OR FLUIDS OF ANY KIND USED SEPARATELY OR AS A MIX WITH BLAST MEDIA**

# **CONTENTS**

---

ASSEMBLY & MAINTENANCE

PARTS LIST & DIAGRAM AIR SYSTEM

PARTS LIST & DIAGRAM CABINET

PARTS LIST & DIAGRAM GUN

PARTS LIST & DIAGRAM LIGHT BOX

MEDIA INFORMATION

TROUBLE SHOOTING CHART

WARRANTY

**ECONOLINE ABRASIVE PRODUCTS**  
**401 N. GRIFFIN**  
**GRAND HAVEN, MI 49417**

**PH: 616-846-4150**  
**TOLL FREE: 1-800-253-9968**  
**FAX: 616-846-6341**

**[www.sandblasting.com](http://www.sandblasting.com)**

# ASSEMBLY OPERATION

Attach lamp box assembly to cabinet. Attach your air line to the safety switch (see assembly diagram). Use ½" inside diameter air hose with a brass hose barb 3/8" NPT. (Smaller I.D. hose will affect cabinet performance by restricting air flow).

Plug dust collector's electric cord into outlet in lamp box assembly. Plug cord from lamp box into your 110 volt 60 cycle electric line.

Attach one end of dust collector hose to dust collector and insert other end into hole in right side or back of cabinet.

To charge the system, pour approximately 25 to 50 pounds of sandblasting media into the hopper of the cabinet through door opening. Note: your media must not cover the air intake end of the siphon tube.

Air pressure may be regulated anywhere between 10 PSI and 120 PSI depending on the job to be done and media used. Most jobs will be done at pressures of 60 PSI to 80 PSI. Remember when using glass bead, media pressures above 80 PSI will cause your media to fracture and turn to dust.

Softer metals and materials or delicate parts should be cleaned at lower pressures. Non-critical parts requiring rapid cleaning may be done with higher air pressures for speed. Bear in mind that abrasives break down, and nozzles wear out twice as fast at 110 PSI than they do at 80 PSI.

For best results, operator should provide continuous gun movement over work surface, feathering media to produce consistent finish. Lower pressure produces finer finishes.

To blast, insert arms into gloves, grasp blast gun and depress foot pedal.

## MAINTENANCE

---

Check gun's blast nozzle and air jet occasionally for signs of wear. When the opening inside the nozzle becomes too large, the result will be a poor blast pattern. If the gun fails to throw media, check abrasive hose, siphon tube and gun body for blockage. Excessive wear of air jet will also cause poor or complete loss of abrasive flow.

Water and/or oil in your air line will cause problems with the efficiency of your blasting. Before blasting, always drain water and/or oil from your air lines and compressor. We suggest a quality water filter be installed in the air line between compressor and blast cabinet.

Good visibility speeds up work; Clean dust from window often and replace the plastic window underlayment and window when needed. The lampshield will also become frosted and require replacement. Visibility is also greatly affected by the condition and type of dust collection system you use. Filters should be cleaned often and dust emptied from canister regularly (more than a gallon of debris is too much).

If after extended use of the machine the gasket around the door or window(s) becomes damaged or worn, it can be replaced (see diagram and parts list for cabinet).

This equipment is designed to the finest point of simplicity. With reasonable care it should give you many years of excellent service.

Blasting by its very nature is a high maintenance process. The same forces acting to separate materials from targeted pieces wear on the system itself.

Keep spare parts in stock to avoid down time.

## **PARTS LIST FOR AIR SYSTEM (24-0BB & 36-0 B)**

---

<b><u>DESCRIPTION</u></b>	<b><u>PART NUMBER</u></b>
1. Abrasive Hose - specify # of ft req.	413403
2. Gun Hose -28" (for 24-0 BB)	201881
40" (for 36-0 B)	201883
3. Air inlet connecting air hose from foot pedal to cabinet	411100
3a. Hex nut 3/4" – 16 for air inlet	411551
4. Trap Door	201325-66
5. Trap Door Gasket	410545
6. Trap Door Spring – (for 24-0 BB)	411600
(for 36-0 B)	411601
7. Siphon Tube – (for 24-0 BB)	310497
(for 36-0 B)	201785
8. Gun Assembly	201788

Call 1-800-253-9968 for assistance in locating an ECONOLINE distributor in your area

**ASSEMBLY DIAGRAM FOR AIR SYSTEM**

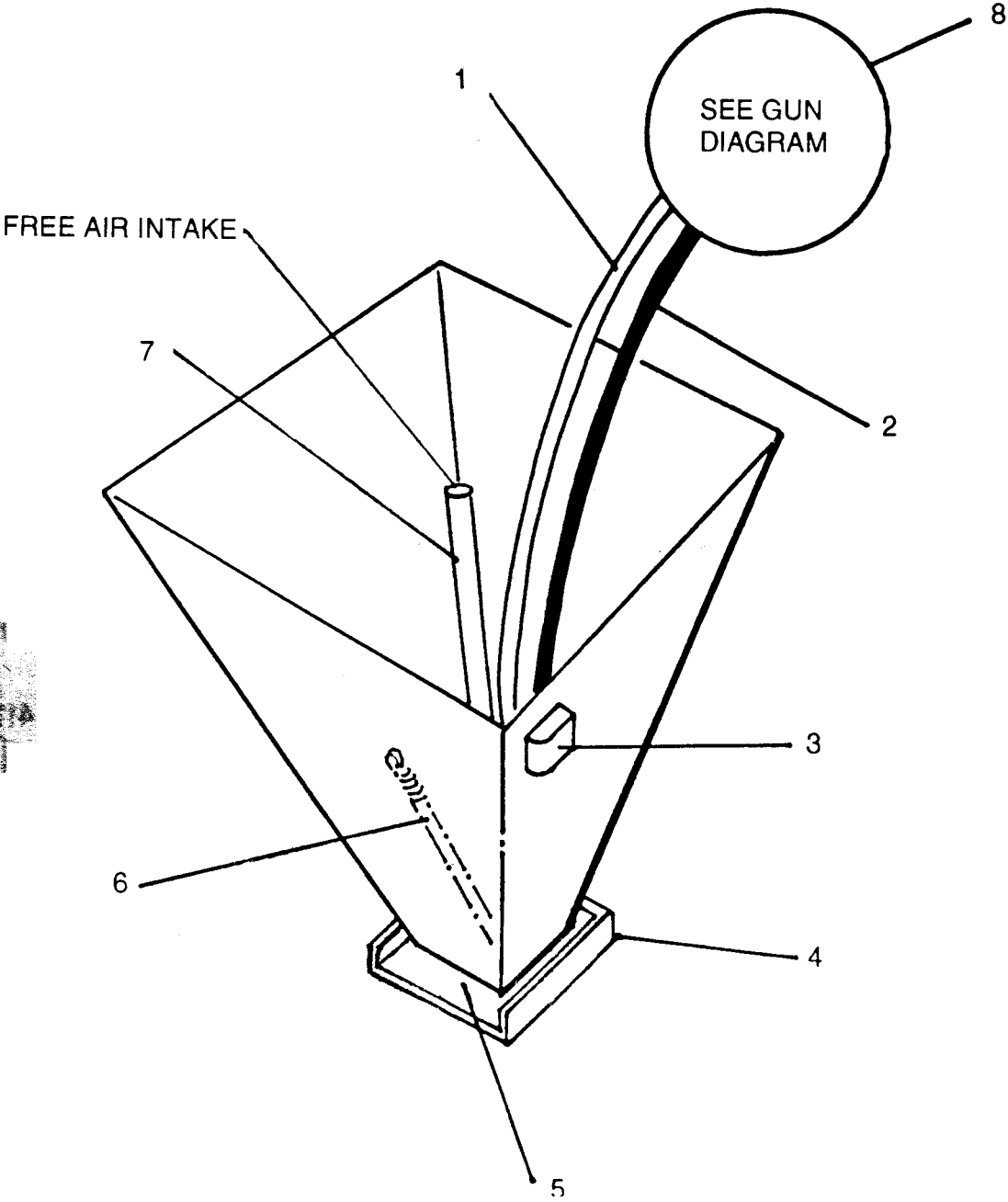

## **PARTS LIST FOR BLAST CABINET 24-0 BB & 36-0 B**

---

<b><u>DESCRIPTION</u></b>	<b><u>PART NUMBER</u></b>
9. Lampbox Assembly	202836-led
10. Window Frame (for 24-0BB) (for 36-0 B)	309430-66 309344-66
11. Window Plexi-glass 11.8 x 11.3 (for 24-0 BB) 12 x 24 (for 36-0 B)	411412 411405
12. Window Underlayment – 12 x 24 precut – 10 per roll 12 x 120 – roll	313286 311535
13. Window Gasket – ½ x 1 – specify # of ft. req.	411403
14. Armhole gasket ¼” x 1” - Specify # of ft req.	411402
15. Front Latch	411712
16. Trap Door Gasket	410545
17. Adjustable Legs - for 24-0 BB only	
18. Front Door Gasket ½ x 1 – specify # of ft. req.	411403
19. Lampbox Gasket - ½ x 1 – specify # of ft. req.	411403
20. Lampshield	411423
Not Shown –	
Expanded Metal Floor (for 24-0 BB) (for 36-0 B)	201348 201345
Gloves – 24-6 cotton lined - Pair	412002
Glove Clamps – 2 required	414511-2

---

**Call 1-800-253-9968 for assistance in locating an ECONOLINE distributor in your area**



\*\*Diagram shown is 24-0 BB which has bolt on legs. The 36-0 has welded on legs.\*\*

### ASSEMBLY DIAGRAM FOR BLAST CABINET

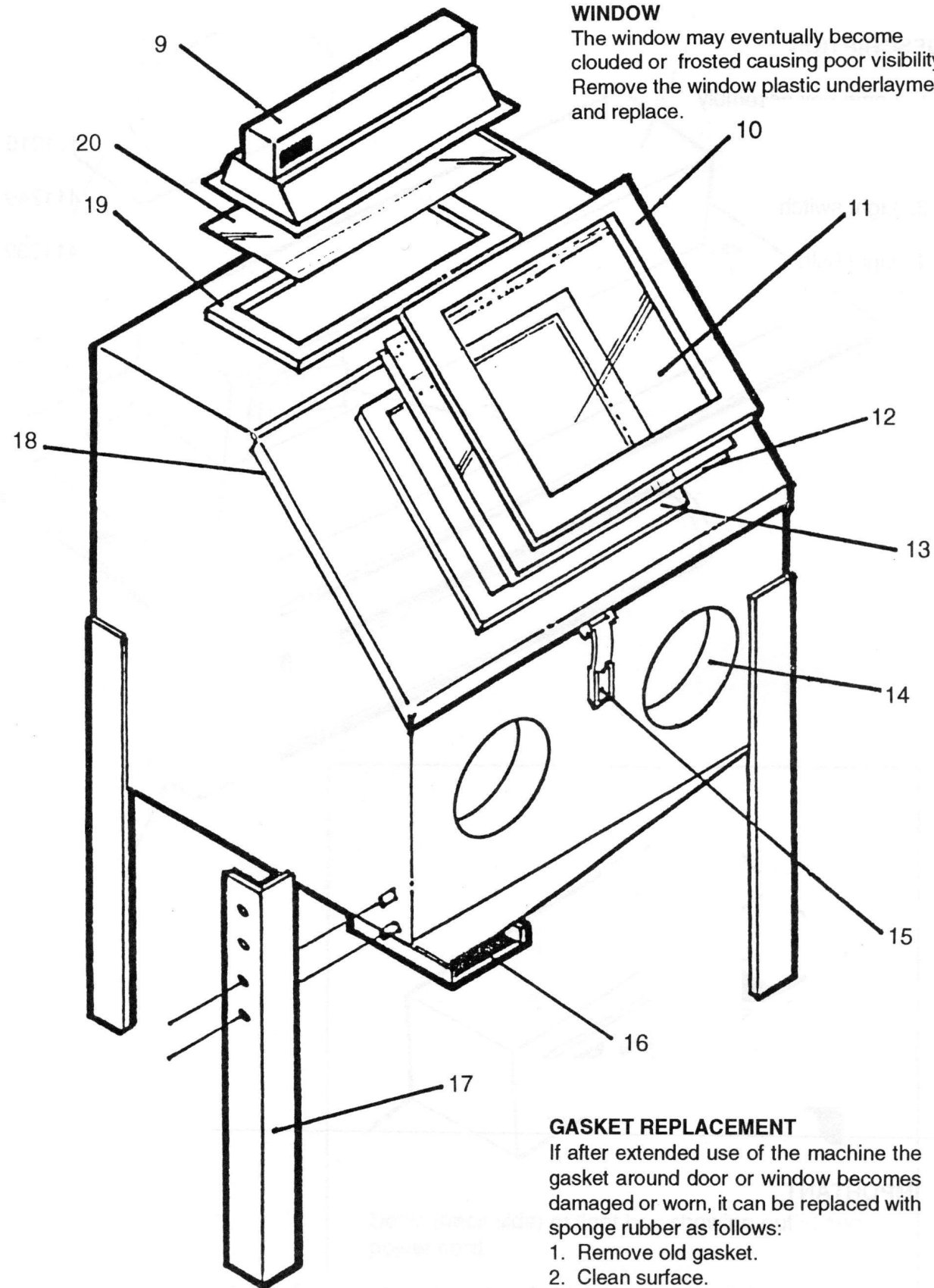

**WINDOW**  
The window may eventually become clouded or frosted causing poor visibility. Remove the window plastic underlayment and replace.

**GASKET REPLACEMENT**  
If after extended use of the machine the gasket around door or window becomes damaged or worn, it can be replaced with sponge rubber as follows:  
1. Remove old gasket.  
2. Clean surface.  
3. Affix new gasket to cleaned surface.

# PARTS LIST FOR 12 CFM TRIGGER GUN

Description	Catalog #	Part #
1. Gun Body		410535B
2. Nozzle holder		410535A
3. Nozzle assembly 12 CFM		201790
4. Air jet 12 CFM		410537
5. Gun assembly complete		201788

## NOZZLE ASSEMBLY

Nozzle assembly 12CFM \_\_\_\_\_ #201790  
 Nozzle assembly 25CFM \_\_\_\_\_ #201791

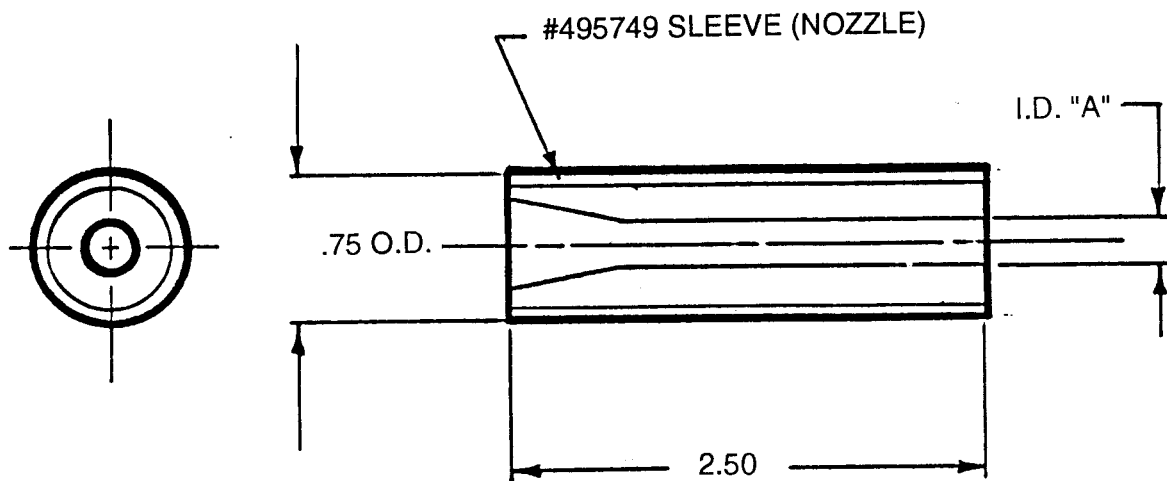

I.D. "A" = 1/4" #201790 Nozzle assembly 12CFM  
 I.D. "A" = 5/16" #201791 Nozzle assembly 25CFM

## IMPORTANT

Replacement and service parts may be ordered by using either catalog or part number listed above.

Call 1-800-253-9968 for assistance in locating an ECONOLINE distributor in your area.

## ASSEMBLY DIAGRAM FOR 12 CFM TRIGGER GUN

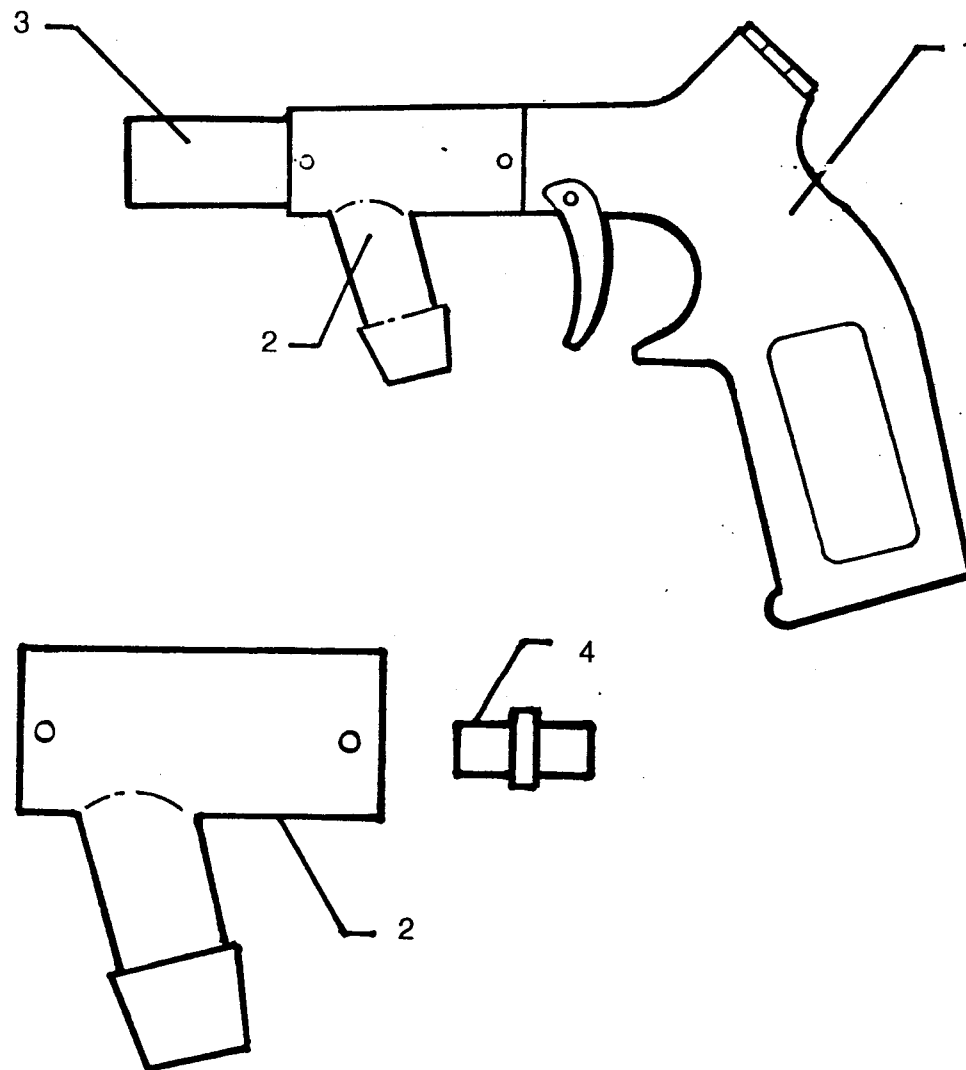

This blast gun is designed to create a static vacuum. This vacuum draws abrasive through siphon tube and abrasive hose into gun body, where compressed air pushes media through blast nozzle.

Maintenance and repair of this gun can be done quickly and simply. Loosen allen head screws in gun body to remove and inspect nozzle and air jet for wear.

Excessive wear on either of these parts will cause poor abrasive flow, and blast pattern.

To extend life of gun assembly it is important to rotate the air jet and nozzle in gun body regularly.

# PARTS LIST FOR SMALL LIGHT BOX COMPLETE ASSEMBLY #202836-LED

<u>DESCRIPTION</u>	<u>PART NUMBER</u>
1. Light Box cover only	410467
2. Light bulb led A19 / 5000k / 9 watt	411241
3. Light bulb socket	411248
4. Nut for socket (not shown)	411247
5. Light switch (on/off)	411249
6. Lamp Shield	411423
7. Power Cord	411242



## IMPORTANT

Call 1-800-253-9968 for assistance in locating an ECONOLINE distributor in your area.

# ABRASIVES

Econoline Abrasive Products strives to maintain a varied inventory of blasting abrasives. Utilizing a worldwide base of reputable suppliers, Econoline is able to provide consistent delivery of quality abrasive products. Econoline looks forward to servicing your abrasive needs.

## WHAT MEDIA TO USE

### **Brown Aluminum Oxide**

Widely used as a cutting media. It can produce an “anchor” pattern in preparation for re-coating. It's excellent for removing foreign matter, deburring, frosting glass and lettering stone. It is extremely fast cutting, can be reused many times and is classified in various sizes for a wide selection of finishes.

### **Glass Beads**

Available in a wide range of sizes, glass beads are generally the most popular media used in most cabinets today. This all-purpose media is used for honing, polishing, peening, blending, finishing, removing light burrs and cleaning most light foreign matter such as carbon and other surface residues from pistons and valves. And with no base-metal removal or dimensional change. Weld and solder flaws can also be detected via glass bead blasting.

### **Black Silicon Carbide**

When blasting silicon carbide is extremely fast cutting, this sharp media is used for cleaning very hard surfaces such as tungsten carbide.

### **Plastic**

This new, dust free media is a special formulation of plastic materials that has high tensile, compressive and flexural strength combined with comparatively low hardness. Used for deflashing plastic parts and cleaning molds, dies, electronic connections and circuit boards. It can effectively deburr machined-iron castings and non-ferrous screw machine parts.

	<b>ALUMINUM OXIDE</b>	<b>GLASS BEAD</b>	<b>SILICON CARBIDE</b>	<b>PLASTIC</b>
FINISHING	X	X	X	
CLEANING / REMOVAL	X	X	X	X
SURFACE TREATMENT	X	X	X	
CLEANING SPEED	HIGH	MED	VERY HI	MID-HI
RE-USE	MED-HI	HIGH	MED-LO	MED
DUST LEVEL	HIGH	LO	MED-LO	MED
PROBABILITY OF METAL REMOVAL	MED-HI	VERY-LO	MED-HI	VERY-LO
HARDNESS (MOH SCALE)	8-9	5.5	9	3-4
TYPICAL BLAST PRESSURE	20-90	20-55	20-90	20-60
ANGULAR OR SPHERICAL	ANGULAR	SPHERICAL	ANGULAR	BOTH

# TROUBLESHOOTING CHART

SYMPTOM	POSSIBLE CAUSES	CORRECTIVE ACTION
Too much dust in cabinet	<ol style="list-style-type: none"> <li>1. Exhaust unit not functioning efficiently.</li> <li>2. Media is broken down or deteriorated.</li> </ol>	<ol style="list-style-type: none"> <li>1. All models. Remove lid from exhaust canister and clean cloth filter</li> <li>2. Replace blasting media</li> </ol>
Noticeable speed and efficiency are lost in blasting operation	<ol style="list-style-type: none"> <li>1. Media is broken down or deteriorated from constant use.</li> </ol>	<ol style="list-style-type: none"> <li>1. Replace media</li> </ol>
Static Electricity	<ol style="list-style-type: none"> <li>1. Weather conditions, excessive dust in unit</li> </ol>	<p><b>1. Proceed as follows:</b></p> <ol style="list-style-type: none"> <li>a. Properly ground the machine</li> <li>b. Allow work piece to rest on the work table grating in the unit. This will discharge static electricity through the cabinet into the unit's ground wire.</li> </ol>
Poor Blast Pattern	<ol style="list-style-type: none"> <li>1. Worn nozzle</li> </ol>	<ol style="list-style-type: none"> <li>1. Replace nozzle</li> </ol>
Poor Abrasive Flow	<ol style="list-style-type: none"> <li>1. Abrasive level too low</li> <li>2. Dirty abrasives</li> <li>3. Wet abrasives</li> <li>4. Worn air jet</li> <li>5. Worn nozzle</li> <li>6. Worn siphon tube</li> <li>7. Insufficient air               <ol style="list-style-type: none"> <li>a. When machine stands idle, check pressure gauge. With foot pedal depressed, needle on gauge should not drop below desired blasting pressure</li> <li>b. Needle should hold steady and not drop during blasting</li> </ol> </li> <li>8. Nozzle installed backwards</li> <li>9. Clogged gun</li> <li>10. Plugged siphon tube</li> </ol>	<ol style="list-style-type: none"> <li>1. Add abrasives</li> <li>2. Replace, possibly install filter screen</li> <li>3. Replace, possibly install water filter</li> <li>4. Replace</li> <li>5. Replace</li> <li>6. Replace</li> <li>7. <b>Proceed as follows:</b> <ol style="list-style-type: none"> <li>a. Larger compressor, larger air line, smaller gun</li> <li>b. Larger compressor, smaller gun</li> </ol> </li> <li>8. Cone shaped end should be installed in towards air jet</li> <li>9. Take apart, clean &amp; reassemble</li> <li>10. Check to see that hole is clear on both sides of the siphon tube</li> </ol>

# WARRANTY

## ECONOLINE

THIS PRODUCT HAS BEEN MANUFACTURED AND ENGINEERED TO THE HIGHEST STANDARDS.

## FIVE YEAR WARRANTY

ECONOLINE ABRASIVE PRODUCTS GUARANTEES ITS BLAST CABINETS AGAINST DEFECTS IN MATERIAL AND WORKMANSHIP FOR A PERIOD OF FIVE YEARS FROM THE ESTABLISHED PURCHASE DATE. ECONOLINE WILL REPAIR OR REPLACE, FREE OF CHARGE, ANY DEFECTIVE PARTS DETERMINED TO BE COVERED UNDER THIS WARRANTY BY OUR FACTORY SERVICE PERSONNEL.

THE PARTS MUST BE RETURNED TO THE FACTORY, FREIGHT COLLECT, WITH A LETTER OF EXPLANATION. ON ACCEPTANCE OF CLAIM ECONOLINE WILL REPLACE DEFECTIVE PART.

## CONDITIONS

THIS WARRANTY DOES NOT APPLY IF THE UNIT HAS BEEN MISUSED, ALTERED, OR USED FOR ANY PURPOSE OTHER THAN IN ACCORDANCE WITH THE OPERATING AND ASSEMBLY INSTRUCTIONS PROVIDED.

THIS WARRANTY DOES NOT COVER TRANSPORTATION, INTERIOR OR EXTERIOR FINISHES, HOSE ASSEMBLIES, NOZZLES, AIR JETS, WINDOWS, FILTERS, LAMPSHIELDS OR MEDIA VALVE.

**OPERATION OF THIS UNIT WITH NATURAL SAND SHALL RENDER THIS WARRANTY NULL AND VOID.**

# WARNING

DO NOT USE SAND OR ANY ABRASIVE CONTAINING SILICA.  
USE OF COMPOUNDS CONTAINING SILICA IS A HEALTH  
HAZARD.

FREE SILICA WHEN INHALED CAN LEAD TO SERIOUS,  
PERMANENT, DISABLING AND DEADLY DISEASE (SILICOSIS).